



VB027SP

HIGH VOLTAGE IGNITION COIL DRIVER POWER I.C.

TYPE	V _{cl}	I _{cl}	I _{d(on)}
VB027SP	300V	9A	130mA

- PRIMARY COIL VOLTAGE INTERNALLY SET
- COIL CURRENT LIMIT INTERNALLY SET
- LOGIC LEVEL COMPATIBLE INPUT
- DRIVING CURRENT QUASI PROPORTIONAL TO COLLECTOR CURRENT
- DOUBLE FLAG-ON COIL CURRENT

DESCRIPTION

The VB027SP is a high voltage power integrated circuit made using the STMicroelectronics VIPower™ technology, with vertical current flow power darlington and logic level compatible driving circuit. Built-in protection circuit for coil current limiting and collector voltage clamping allows the device to be used as smart, high

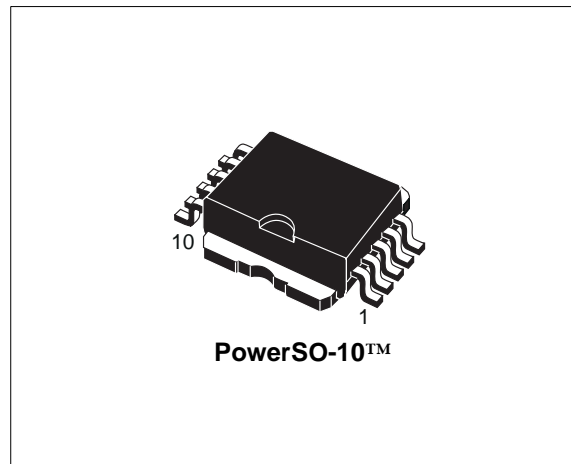

voltage, high current interface in advanced electronic ignition system.

BLOCK DIAGRAM

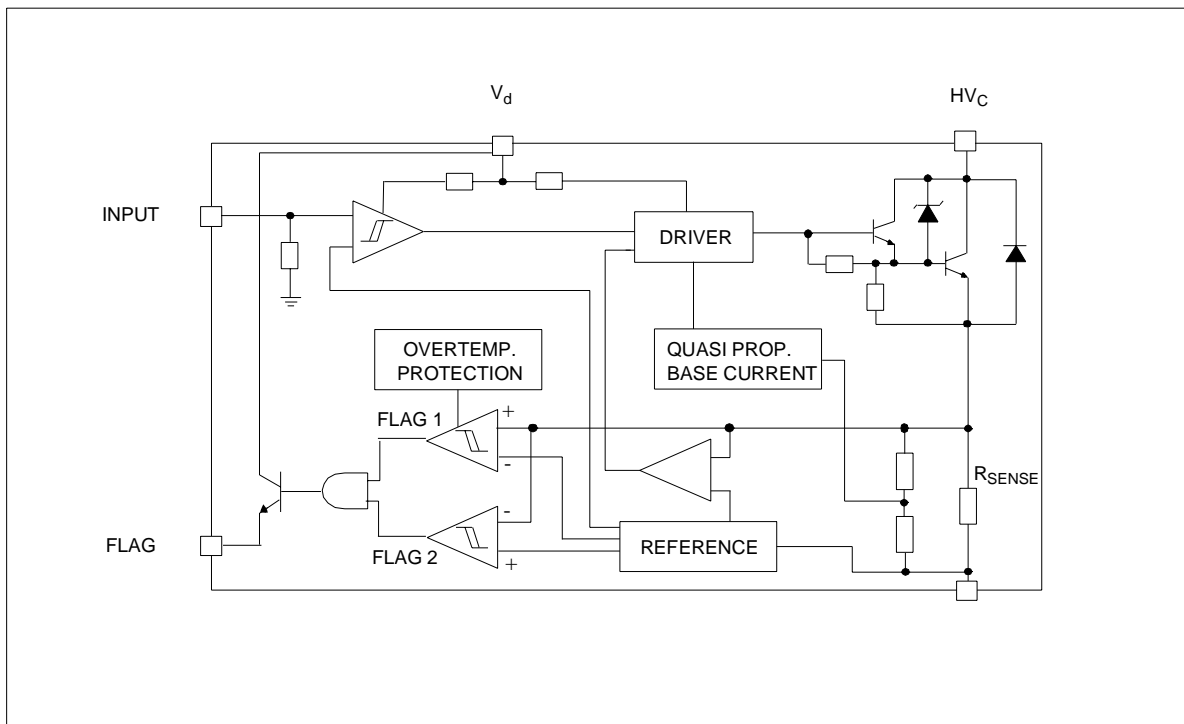

VB027SP

ABSOLUTE MAXIMUM RATING

Symbol	Parameter	Value	Unit
HV_C	Collector voltage	Internally limited	V
I_C	Collector current	Internally limited	A
V_d	Driving stage supply voltage	7	V
I_d	Driving circuitry supply current	200	mA
V_{IN}	Input voltage	10	V
T_j	Junction operating temperature	-40 to 150	°C
T_{stg}	Storage temperature	-55 to 150	°C

THERMAL DATA

Symbol	Parameter	Value	Unit
$R_{thj-case}$	Thermal resistance junction-case (MAX)	1.12	°C/W
$R_{thj-amb}$	Thermal resistance junction-ambient (MAX)	62.5	°C/W

CONNECTION DIAGRAM (TOP VIEW)

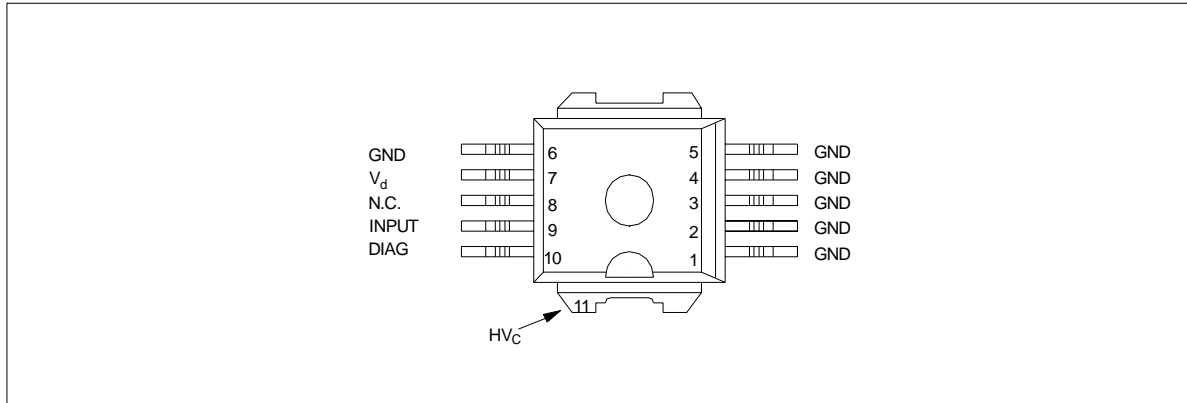

PIN FUNCTION

No	Name	Function
1÷5	GND	Emitter power ground
6(*)	GND	Control ground
7	V_d	Driving stage supply voltage
8	N.C.	
9	INPUT	Logic input channel
10	DIAG	Diagnostic output signal
TAB	HV_C	Primary coil output signal

(*) Pin 1÷5=Power GND, Pin 6=signal GND. Pin 6 must be connected to pins 1÷5 externally.

ELECTRICAL CHARACTERISTICS ($V_{CC}=13.5V$; $V_d=5V$; $T_j=25^\circ C$; $R_{coil}=510m\Omega$; $L_{coil}=7mH$ unless otherwise specified)

Symbol	Parameter	Test Conditions	Min	Typ	Max	Unit
V_{cl}	High voltage clamp	$V_{IN}=0.4V$; $-40^\circ C \leq T_j \leq 125^\circ C$; $I_C=6A$	300	360	400	V
$V_{cg(sat)}$	Power stage saturation voltage	$I_C=6A$; $V_{IN}=4V$; $I_d=80mA$		1.5		V
$V_{cg(sat)td}$	Power stage saturation voltage derating in temperature	$I_C=6A$; $V_{IN}=4V$; $-40^\circ C \leq T_j \leq 125^\circ C$; $I_d=85mA$			2	V
$I_{d(off)}$	Power-off supply current	$V_{IN}=0.4V$			8	mA
$I_{d(on)}$	Power-on supply current	$V_{IN}=4V$; $I_C=6A$; $-40^\circ C \leq T_j \leq 125^\circ C$			130	mA
V_d	Driving stage supply voltage		4.5		5.5	V
I_{cl}	Collector current limit	$V_{IN}=4V$ (See note 1)	8	8.5	9	A
$I_{cl(td)}$	Collector current limit drift with temperature	See figure 3				
V_{INH}	High level input voltage	$HV_C < 2V$	4		5.5	V
V_{INL}	Low level input voltage	$I_C < 2mA$; $HV_C = V_{CC}$	0		0.8	V
I_{INH}	High level input current	$V_{IN}=4V$	40		200	μA
V_{diagH}	High level diagnostic output voltage	$R_{EXT}=22K\Omega$ (See figure 1)	3.5	(*)	V_d	V
V_{diagL}	Low level diagnostic output voltage	$R_{EXT}=22K\Omega$ (See figure 1)			0.5	V
$I_{C(diag1)}$	First threshold level collector current		4.25	4.5	4.75	A
$I_{C(diag1)td}$	First threshold level collector current drift with temperature	See figure 4				
$I_{C(diag2)}$	Second threshold level collector current		5.45	5.8	6.15	A
$I_{C(diag2)td}$	Second threshold level collector current drift with temperature	See figure 5				
$t_{d(off)}$	Turn-off delay time of output current	$I_C=5.5A$		25		μs
$t_{f(off)}$	Turn-off fall time of output current	$I_C=5.5A$		8		μs
$t_{d(diag)}$	Delay time of diagnostic current	$R_{EXT}=22K\Omega$ (See figure 1)		1		μs
$t_{r(diag)}$	Turn-on rise time of diagnostic current	$R_{EXT}=22K\Omega$ (See figure 1)		1		μs
$t_{f(diag)}$	Turn-off fall time of diagnostic current	$R_{EXT}=22K\Omega$ (See figure 1)		1		μs

Note 1: the primary coil current value I_{cl} must be measured 1ms after desaturation of the power stage.

(*) $V_d - V_{be(on)}$

VB027SP

PRINCIPLE OF OPERATION

The VB027SP is mainly intended as high voltage power switch device driven by a logic level input and interfaces directly to a high energy electronic ignition coil.

The input V_{IN} of the VB027SP is fed from a low power signal generated by an external controller that determines both dwell time and ignition point. During V_{IN} high ($\geq 4V$) the VB027SP increases current in the coil to the desired, internally set current level.

When the collector current exceeds 4.5A, the diagnostic signal is turned high and it remains so, until the load current reaches 5.8A (second threshold). At that value, the diagnostic signal is turned low, and the μC forces the V_{IN} to the low state. During the coil current switch-off, the primary voltage HV_C is clamped by a series of Zener diodes at an internally set value V_{cl} , typically 360V.

The collector current sensed through the R_{sense} , is limited thanks to the "Current limiter" block that, as soon as the I_{cl} level is reached, forces the darlington (using the "Driver" block) to limit the current provided.

The transition from saturation to desaturation, coil current limiting phase, must have the ability to accommodate an overvoltage. A maximum overshoot of 20V is allowed.

There can be some short period of time in which the output pin (HV_C) is pulled below ground by a negative current due to leakage inductances and stray capacitances of the ignition coil. This can cause parasitic glitches on the diagnostic output. VB027SP has a built-in protection circuit that allows to lock the p-buried layer potential of the linear stage of the collector power, when the last one is pulled underground.

THERMAL BEHAVIOUR

You can see in the block diagram of the VB027SP a box called overtemperature protection. The purpose of this circuit is to shift the current level at which the first diagnostic is activated down of about 1A.

This information can be managed by the micro that can take the corrective action in order to reduce the power dissipation. This block is not an effective protection but just an overtemperature detection. The shift down of the first flag level cannot be present for temperatures lower than 125°C.

As an example of its behavior you can suppose a very simple motor management system in which the micro does just a simple arithmetic calculation to decide when to switch-off the device after the first flag threshold.

EXAMPLE:

$I_{C(DIAG1)}$ info after x ms ($I_{C(DIAG1)}=2.5A$)

$I_{switch-off}$ info after kx ms.

As soon as the temperature rises over the overtemp threshold, the first diagnostic is shifted down to about 1.5A and, in this example, the switch-off current will be $kx \cdot 1.5 / 2.5$.

OVERVOLTAGE

The VB027SP can withstand the following transients of the battery line:

-100V / 2ms ($R_i=10\Omega$)

+100V / 0.2ms ($R_i=10\Omega$)

+50V / 400ms ($R_i=4.2\Omega$, with $V_{IN}=3V$)

FIGURE 1: Application circuit

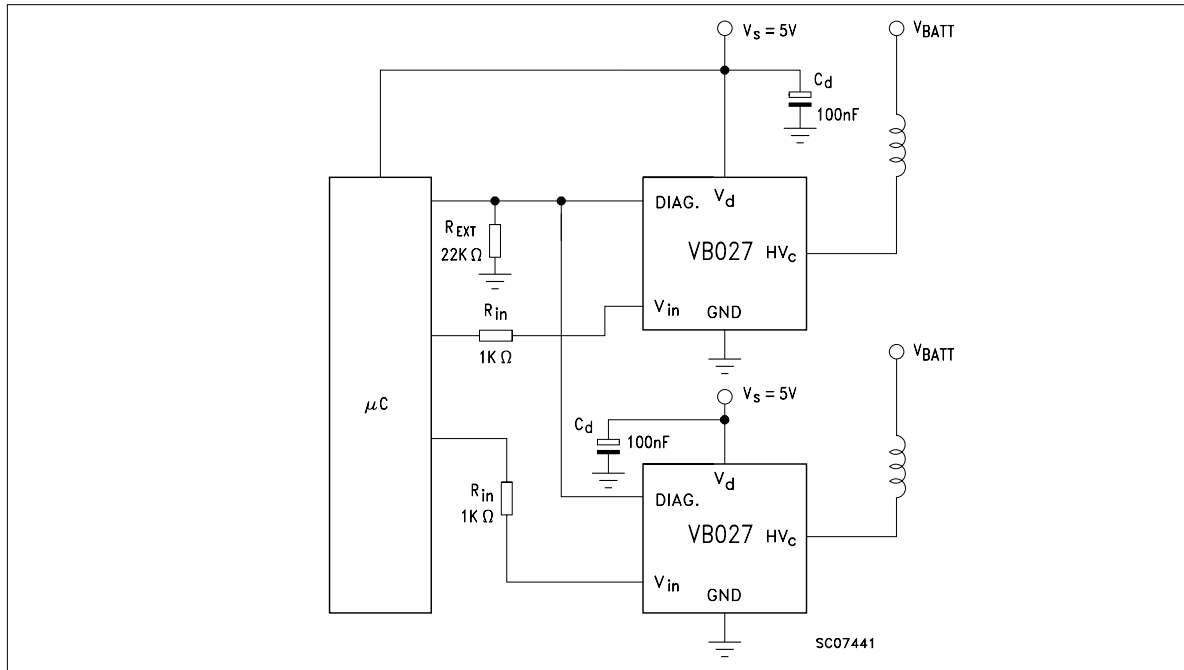

FIGURE 2: Switching waveform

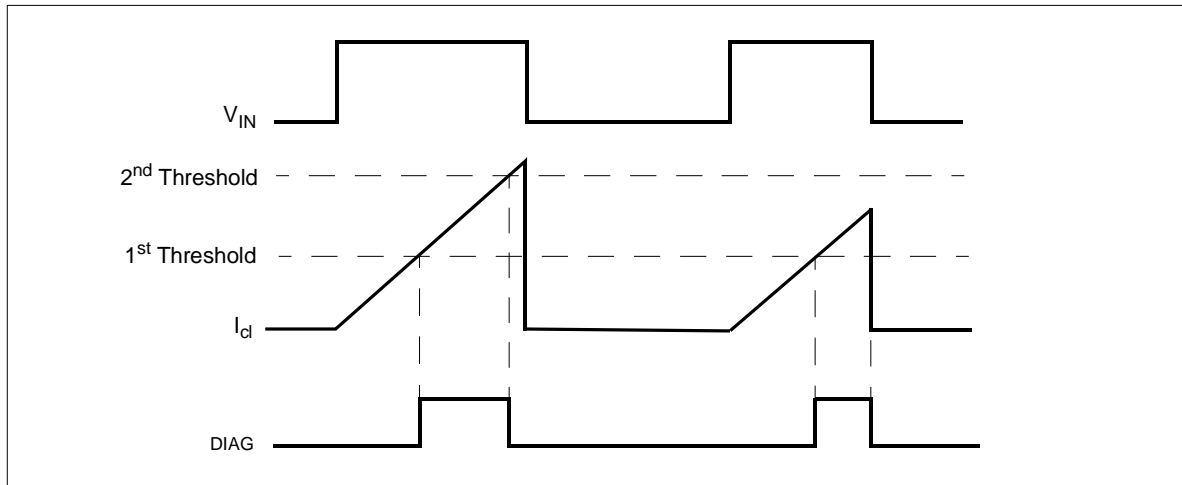

FIGURE 3: Maximum I_{cl} VS temperature

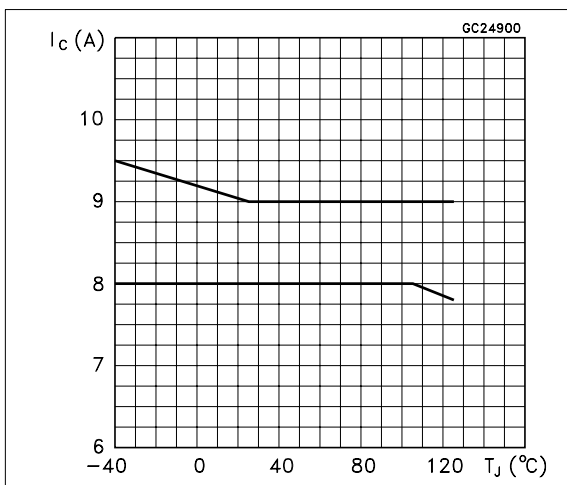

FIGURE 4: $I_{C(diag1)}$ VS temperature

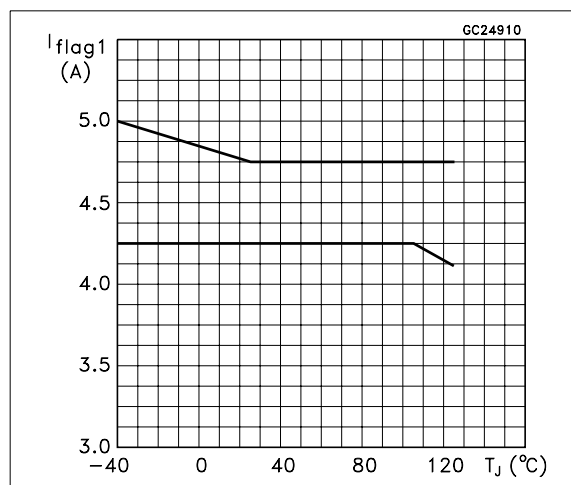
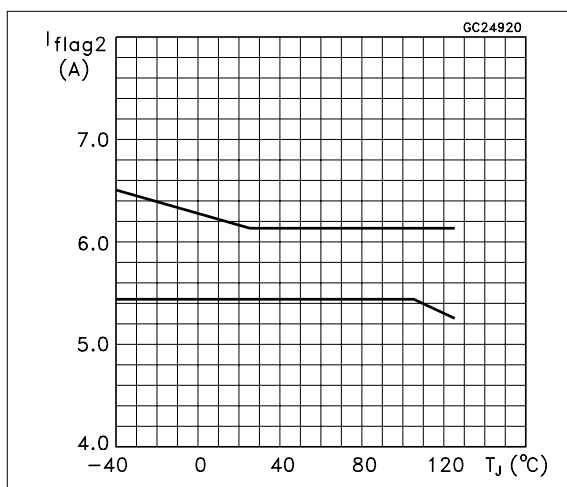
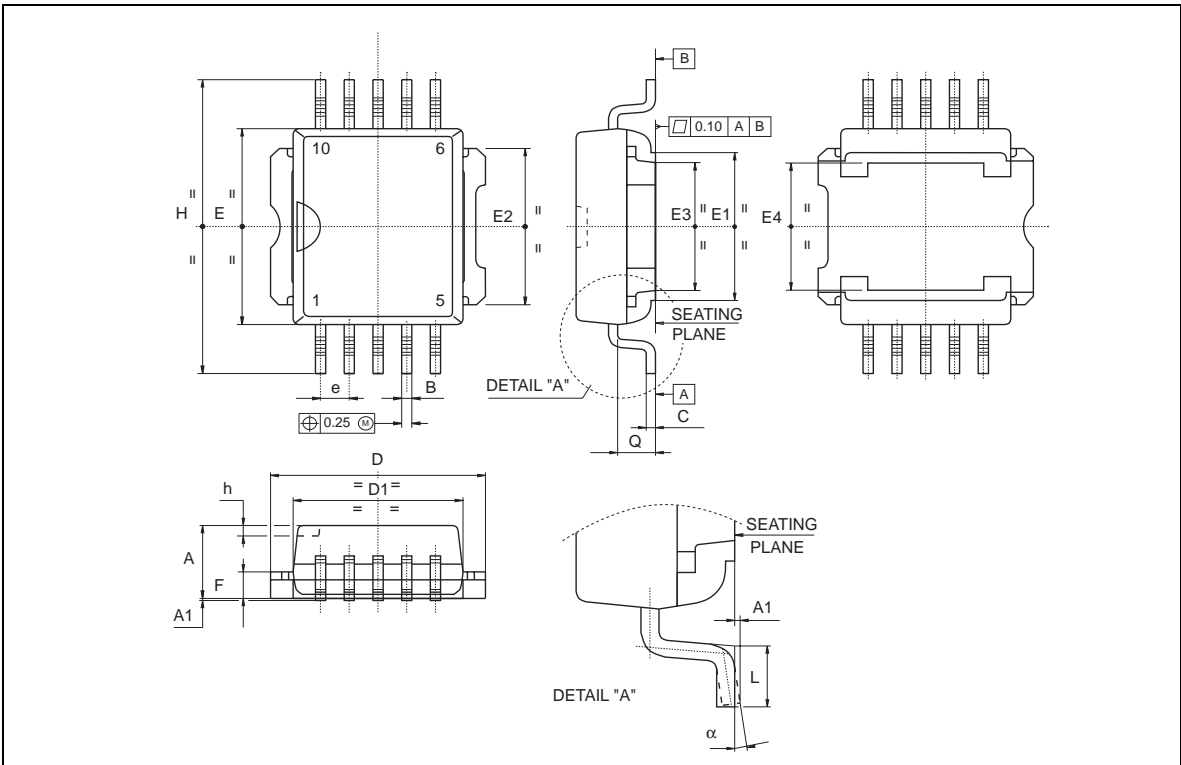

FIGURE 5: $I_{C(diag2)}$ VS temperature



PowerSO-10™ MECHANICAL DATA

DIM.	mm.			inch		
	MIN.	TYP	MAX.	MIN.	TYP.	MAX.
A	3.35		3.65	0.132		0.144
A1	0.00		0.10	0.000		0.004
B	0.40		0.60	0.016		0.024
c	0.35		0.55	0.013		0.022
D	9.40		9.60	0.370		0.378
D1	7.40		7.60	0.291		0.300
E	9.30		9.50	0.366		0.374
E1	7.20		7.40	0.283		0.291
E2	7.20		7.60	0.283		300
E3	6.10		6.35	0.240		0.250
E4	5.90		6.10	0.232		0.240
e		1.27			0.050	
F	1.25		1.35	0.049		0.053
H	13.80		14.40	0.543		0.567
h		0.50			0.002	
Q		1.70			0.067	
α	0°		8°			



Information furnished is believed to be accurate and reliable. However, STMicroelectronics assumes no responsibility for the consequences of use of such information nor for any infringement of patents or other rights of third parties which may result from its use. No license is granted by implication or otherwise under any patent or patent rights of STMicroelectronics. Specifications mentioned in this publication are subject to change without notice. This publication supersedes and replaces all information previously supplied. STMicroelectronics products are not authorized for use as critical components in life support devices or systems without express written approval of STMicroelectronics.

The ST logo is a registered trademark of STMicroelectronics

© 1998 STMicroelectronics - Printed in ITALY- All Rights Reserved.

STMicroelectronics GROUP OF COMPANIES

Australia - Brazil - Canada - China - France - Germany - Italy - Japan - Korea - Malaysia - Malta - Mexico - Morocco -
The Netherlands- Singapore - Spain - Sweden - Switzerland - Taiwan - Thailand - United Kingdom - U.S.A.